

DE	<b>Montageanleitung</b> Schwimmerschalter für KHS Hygienespülung PRO PURE LITE Fig. 689 04 017	»» 2
EN	<b>Installation instructions</b> Float switch for Hygiene Flush Box PRO PURE LITE Fig. 689 04 017	»» 3
FR	<b>Instructions de montage</b> Interrupteur à flotteur pour KHS Hygiene Flush Box PRO PURE LITE Fig. 689 04 017	»» 4
IT	<b>Istruzioni di montaggio</b> Interruttore a galleggiante per KHS Hygiene Flush Box PRO PURE LITE Fig. 689 04 017	»» 5
NL	<b>Montagehandleiding</b> Vlotterschakelaar voor KHS Hygiene Flush Box PRO PURE LITE Fig. 689 04 017	»» 6



**Herstelleradresse**

Gebr. Kemper GmbH + Co. KG  
Harkortstraße 5  
57462 Olpe  
Tel.: +49 2761 891-0  
Web: www.kemper-group.com

**Kundendienst**

Service-Hotline  
Tel.: +49 2761 891 800  
Mail: anwendungstechnik@kemper-group.com

**Über diese Anleitung**

Lesen Sie diese Anleitung vor Montagebeginn oder Gebrauch sorgfältig und folgen Sie den Anweisungen! Bewahren Sie die Anleitung zur späteren Verfügung auf!

Abbildungen in dieser Anleitung dienen dem grundsätzlichen Verständnis und können von der tatsächlichen Ausführung abweichen.

**Haftung**

Der Hersteller leistet keine Gewährleistung oder Haftung bei:

- Nichtbeachten dieser Anleitung.
- fehlerhaftem Einbau und/oder Gebrauch.
- eigenständiger Modifikation am Produkt.
- sonstiger, fehlerhafter Bedienung.

**Sicherheitshinweise**

Beachten und befolgen Sie die Sicherheitshinweise in der Anleitung. Das Nichtbeachten der Sicherheitshinweise kann zum Tod, zu Verletzungen oder zu Sachschäden führen.

Kennzeichnung wichtiger Warnhinweise:

**Warnung!**

Kennzeichnet Gefahren, die zu Verletzungen, Sachschäden oder Verunreinigung des Trinkwassers führen können.

**Hinweis!**

Kennzeichnet Gefahren, die zu Schäden an der Anlage oder Funktionsstörungen führen können.

**Warnung!**

Verletzungsgefahr durch unsachgemäße Montage!

- Die Montage und Wartung darf nur durch eine Sanitärfachkraft erfolgen.

**Manufacturer's address**

Gebr. Kemper GmbH + Co. KG  
Harkortstraße 5  
57462 Olpe  
Tel.: +49 2761 891-0  
Web: [www.kemper-group.com](http://www.kemper-group.com)

**After-sales service**

Service hotline  
Tel.: +49 2761 891 800  
Email: [anwendungstechnik@kemper-group.com](mailto:anwendungstechnik@kemper-group.com)

**About this manual**

Read this manual carefully before starting assembly, use and maintenance and follow the instructions! Retain the manual for later reference! Illustrations in this manual serve to aid basic understanding and may differ from the actual system configuration.

**Liability**

The manufacturer assumes no warranty or liability in case of:

- failure to follow these instructions
- incorrect installation and/or use
- unauthorised modification of the product
- other improper methods of operation.

**Safety instructions**

Be sure to read and follow the safety instructions in this manual. Failure to follow the safety instructions can result in injury or even death and in damage to property.

Labelling of important warning information:

**Warning!**

Indicates hazards that may result in injury, damage to property or contamination of drinking water.

**Note!**

Indicates hazards that may result in damage to the Hygiene Flush Box or malfunctions.

**Warning!**

Risk of injury due to improper installation!

- Assembly and maintenance may only be carried out by a plumbing specialist.

**Adresse du fabricant**

Gebr. Kemper GmbH + Co. KG  
Harkortsstraße 5  
57462 Olpe  
Tél.: +49 2761 891-0  
Site Internet: [www.kemper-group.com](http://www.kemper-group.com)

**Service après-vente**

Ligne d'assistance téléphonique du service après-vente  
Tél.: +49 2761 891 800  
E-mail: [anwendungstechnik@kemper-group.com](mailto:anwendungstechnik@kemper-group.com)

**A propos de cette notice**

Lisez soigneusement la notice avant le montage ou l'utilisation et respectez les instructions! Conservez la notice comme référence à l'avenir!  
Les illustrations de cette notice ont pour but de donner au lecteur une compréhension de base et peuvent diverger du modèle existant.

**Responsabilité**

Le fabricant n'assume aucune responsabilité ni aucune garantie:

- en cas de non-respect de cette notice,
- en cas d'installation et/ou d'utilisation incorrecte(s),
- en cas de modification autonome du produit et
- en cas de toute autre utilisation inappropriée.

**Consignes de sécurité**

Tenez compte et respectez impérativement les consignes de sécurité indiquées dans cette notice. Le non-respect des consignes de sécurité peut entraîner la mort, des blessures ou des dommages matériels.

Marquage des avertissements importants:

**Avertissement!**

Indique les dangers pouvant entraîner des blessures, des dégâts matériels ou une contamination de l'eau potable.

**Remarque!**

Indique les dangers pouvant entraîner des détériorations sur le KHS Hygiene Flush Box ou des dysfonctionnements.

**Avertissement!**

Risque de blessures en cas de montage incorrect!

- Uniquement un spécialiste en sanitaire est autorisé à effectuer le montage et l'entretien.

**Indirizzo del produttore**

Gebr. Kemper GmbH + Co. KG  
Harkortstraße 5  
57462 Olpe  
Tel.: +49 2761 891-0  
Web: [www.kemper-group.com](http://www.kemper-group.com)

**Servizio clienti**

Service-Hotline  
Tel.: +49 2761 891 800  
E-mail: [anwendungstechnik@kemper-group.com](mailto:anwendungstechnik@kemper-group.com)

**Informazioni su queste istruzioni**

Leggere con attenzione le presenti istruzioni prima di procedere al montaggio e all'utilizzo. Attenersi alle indicazioni fornite! Conservare le istruzioni per poterle consultare in seguito!

Le immagini riportate in queste istruzioni hanno lo scopo di agevolare la comprensione di base e possono differire dall'effettiva versione dell'impianto.

**Responsabilità**

Il produttore non fornisce alcuna garanzia né si assume alcuna responsabilità in caso di:

- mancata osservanza delle presenti istruzioni
- installazione e/o utilizzo errato
- modifica arbitraria del prodotto
- altro impiego non conforme.

**Avvertenze di sicurezza**

Rispettare e seguire scrupolosamente le avvertenze di sicurezza riportate in queste istruzioni. La mancata osservanza delle avvertenze di sicurezza può essere causa di morte, lesioni o danni materiali.

Indicatori delle avvertenze importanti:

**Attenzione!**

Indica i pericoli che possono essere causa di lesioni, danni materiali o inquinamento dell'acqua potabile.

**Nota!**

Indica i pericoli che possono causare danni all'impianto o malfunzionamenti.

**Attenzione!**

Pericolo di lesioni per montaggio non corretto!

- Montaggio e manutenzione devono essere eseguiti esclusivamente da personale specializzato in impianti sanitari.

**Adres van de fabrikant**

Gebr. Kemper GmbH + Co. KG  
Harkortstraße 5  
57462 Olpe  
Tel.: +49 2761 891-0  
Web: www.kemper-group.com

**Technische dienst**

Service hotline  
Tel.: +49 2761 891 800  
Mail: anwendungstechnik@kemper-group.com

**Over deze handleiding**

Lees deze handleiding zorgvuldig door voordat u begint met de installatie en het gebruik en volg de instructies op! Bewaar deze handleiding goed, zodat u haar later weer kunt raadplegen! Afbeeldingen in deze handleiding dienen voor het begrip van de werking en kunnen afwijken van de daadwerkelijke uitvoering.

**Aansprakelijkheid**

De fabrikant verleent geen garantie en stelt zich niet aansprakelijk bij:

- het negeren van deze handleiding
- incorrecte inbouw en/of incorrect gebruik
- eigenmachtige wijziging van het product
- andere foutieve bediening.

**Veiligheidsinstructies**

Neem de veiligheidsinstructies in de handleiding in acht en volg ze op. Het niet in acht nemen van de veiligheid-sinstructies kan leiden tot de dood, letsel of materiële schade.

Markering belangrijke waarschuwingen:

**Waarschuwing!**

Markeert gevaren die tot letsel, materiële schade of verontreiniging van het drinkwater kunnen leiden.

**Aanwijzing!**

Markeert gevaren die tot schade aan de hygiënespoeler of tot functiestoringen kunnen leiden.

**Waarschuwing!**

Letselgevaar door onvakkundige montage!  
Montage mogen alleen door een loodgieter worden uitgevoerd.



Vorbereitung · Preparation · Préparatifs · Preparazione ·  
Voorbereiding

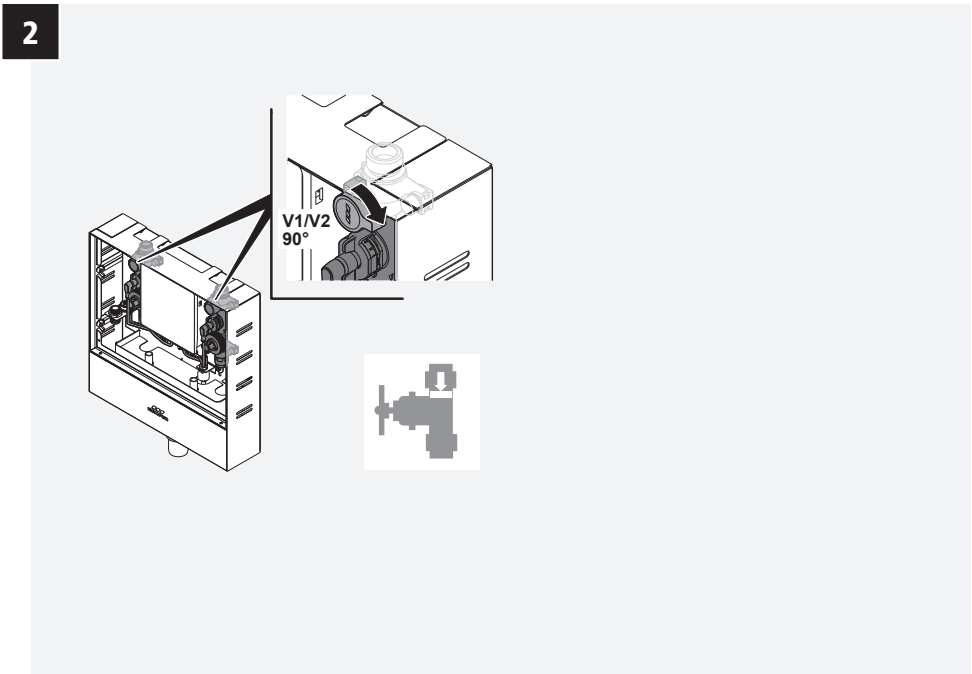
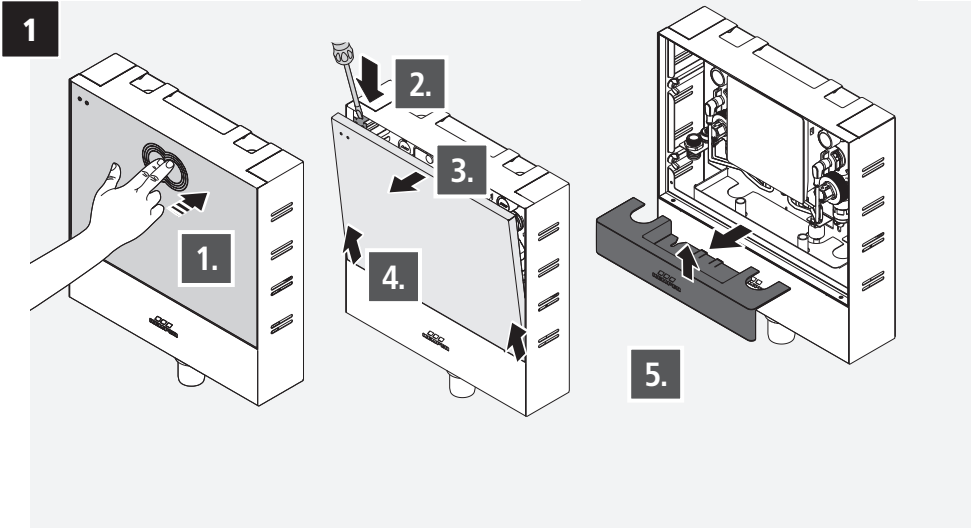



Schwimmerschalter tauschen · Float switch replacement ·  
Remplacer l'interrupteur à flotteur · Sostituzione  
interruttore a galleggiante · Vlotterschakelaar vervangen

1

Demontage · Dismantling · Démontage · Smontaggio ·  
Demontage

1

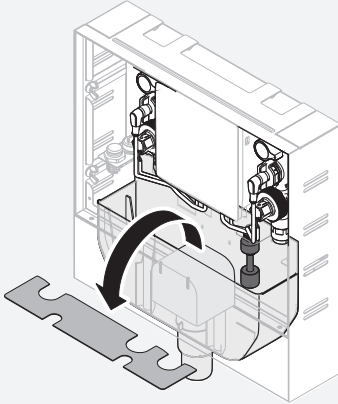

2

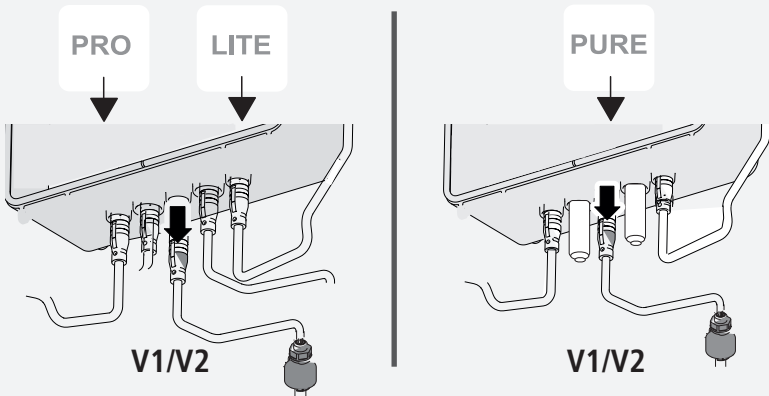

**i**

**DE Info!** Nach dem Abziehen des Schwimmer-Steckers wird eine Störmeldung ausgelöst. Ignorieren Sie diese und fahren Sie fort.

**EN Info!** After pulling the plug from the float switch an alarm message is triggered. Ignore this message and continue.

**FR Info!** Après avoir retiré le bouchon flotteur, un message d'erreur est déclenché. Ignorez-le et continuez.

**IT Info!** Dopo aver rimosso il connettore del galleggiante, viene emesso un messaggio di errore ignorali e vai avanti.

**NL Info!** Na het loskoppelen van de vlotterchakelaar wordt een storingsmelding gegeven. Negeer dit en ga verder.

**3**

**DE** Demontieren Sie den vorhandenen Schwimmerschalter, indem Sie die Befestigung lösen und montieren Sie anschließend den neuen Schwimmerschalter.

**EN** Remove the float switch by unfastening the fixation and install the new float switch.

**FR** Démonter l'interrupteur à flotteur existant en desserrant la fixation puis monter le nouvel interrupteur à flotteur.

**IT** Smontare l'interruttore a galleggiante esistente rimuovendo il fissaggio quindi allentare e montare il nuovo interruttore a galleggiante.

**NL** Demonteer de bestaande vlotterchakelaar door de bevestiging los te maken en monteer vervolgens de nieuwe vlotterchakelaar. Monteer vervolgens de nieuwe vlotterchakelaar.

**2**

## Einbau · Installation · Installation · Montaggio · Inbouw

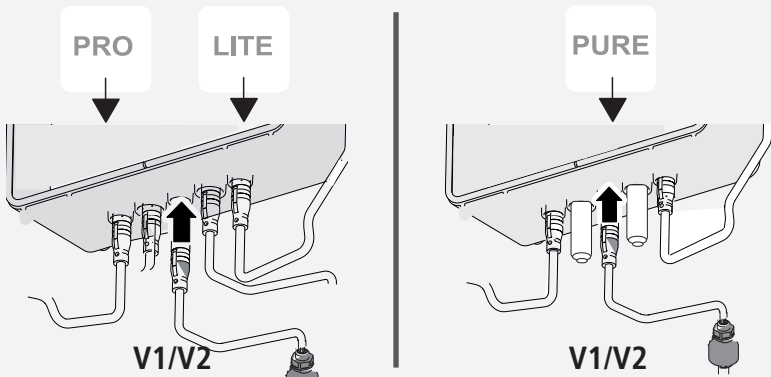
**1**

**2**

DE Fehler quittieren  
 EN Confirm error  
 FR Confirmer l'erreur  
 IT Conferma messaggio di errore  
 NL Fout bevestigen

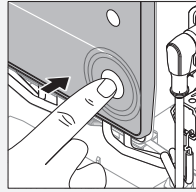
**PRO****1.**

PRESS

**2.**

PRESS

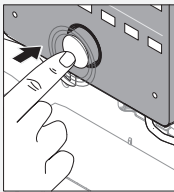
**PURE****1.**

PRESS

**2.**

PRESS

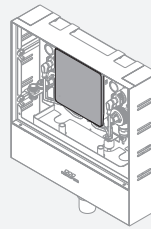
**LITE****3**

DE Führen Sie einen Funktionstest des Schwimmerschalter durch.  
 EN Perform a function test of the float switch.  
 FR Effectuer un test de fonctionnement de l'interrupteur à flotteur.  
 IT Eseguire un test funzionale del Interruttore a galleggiante.  
 NL Test de werking van de vlotterschakelaar.

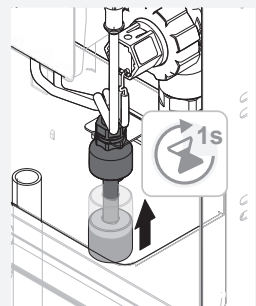

4

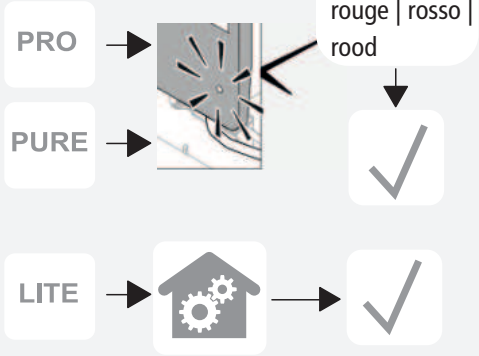

5

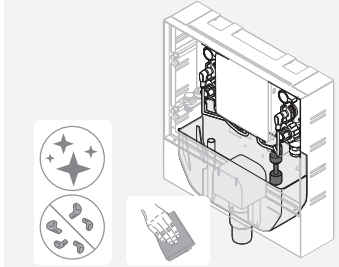

6

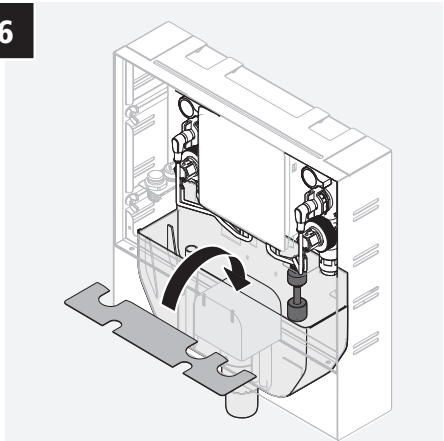

7

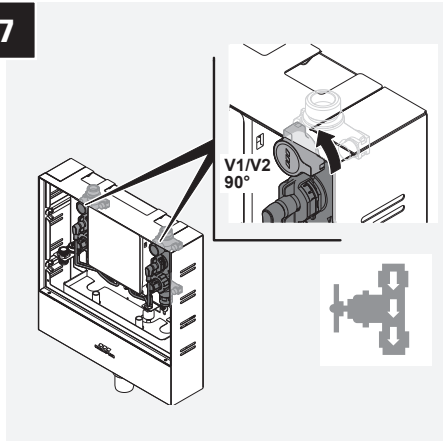

8

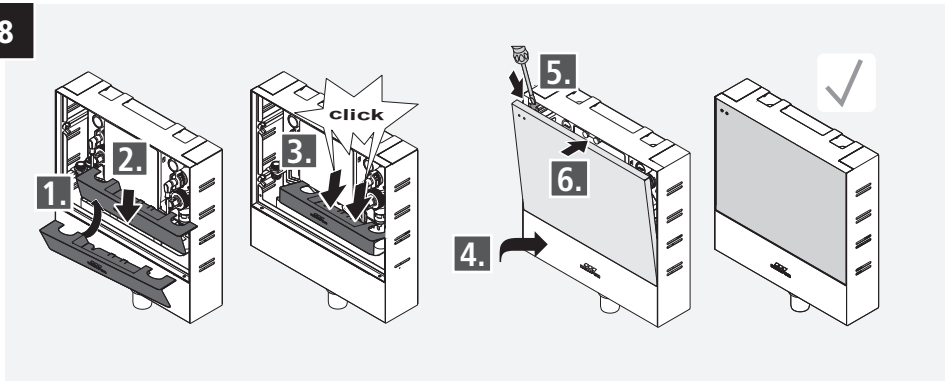

  
FORTSCHRITT MACHEN

**Gebr. Kemper GmbH + Co. KG**  
Harkortstraße 5  
D-57462 Olpe



Service-Hotline +49 2761 891-800  
[www.kemper-group.com](http://www.kemper-group.com)  
[info@kemper-group.com](mailto:info@kemper-group.com)

K410068903007-00 / 08.2024