

DE **Montageanleitung**
Wechseldeckel mit Zugriffsschutz
für KHS Hygienespülung PRO|PURE|LITE
Fig. 689 04 026

EN **Installation instructions**
Reversible cover against unauthorized access
for KHS Hygiene Flush Box PRO|PURE|LITE
Fig. 689 04 026

FR **Instructions de montage**
Couvercle interchangeable avec protection d'accès
pour KHS Hygiene Flush Box PRO|PURE|LITE
Fig. 689 04 026

IT **Istruzioni di montaggio**
Coperchio intercambiabile con protezione di accesso
per KHS Hygiene Flush Box PRO|PURE|LITE
Fig. 689 04 026

NL **Montagehandleiding**
Afdekplaat met plaatborging
voor KHS Hygiene Flush Box PRO|PURE|LITE
Fig. 689 04 026

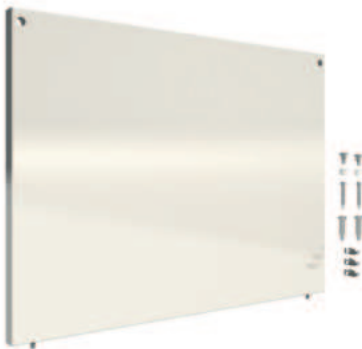

DE

Inhaltsverzeichnis

Über diese Anleitung	4
Lieferumfang	6
Vorbereitung	6
1 Unterputzmontage	7
1.1 Ausrichtung des Einbaurahmens	7
1.2 Abmaße Wechseldeckel	8
1.3 Wechseldeckel auffüllen	9
1.4 Montage Wechseldeckel Unterputz	10
2 Aufputzmontage	13
2.1 Ausrichtung des Einbaurahmens	13
2.2 Montage Wechseldeckel Aufputz	15

EN

Table of contents

About this manual	4
Scope of delivery	6
Preparation	6
1 Flush-mounted installation	7
1.1 Alignment of mounting frame	7
1.2 Dimensions reversible cover	8
1.3 Fill in reversible cover	9
1.4 Installation flush-mounted reversible cover	10
2 Surface-mounted installation	13
2.1 Alignment of mounting frame	13
2.2 Installation surface-mounted reversible cover	15

FR

Sommaire

A propos de cette notice	4
Contenu de livraison	6
Préparatifs	6
1 Montage encastré	7
1.1 Alignement du cadre de montage	7
1.2 Dimension du couvercle interchangeable	8
1.3 Remplir le couvercle interchangeable	9
1.4 Montage du couvercle interchangeable encastré	10
2 Montage apparent	13
2.1 Alignement du cadre de montage	13
2.2 Montage du couvercle interchangeable apparent	15

IT

Indice

Informazioni su queste istruzioni	5
Fornitura in dotazione	6
Preparazione	6
1 Montaggio a incasso	7
1.1 Allineamento del telaio di montaggio	7
1.2 Dimensioni di coperchio	8
1.3 Compilare coperchio intercambiabile	9
1.4 Montaggio di coperchio intercambiabile incasso	10
2 Montaggio a parete	13
2.1 Allineamento del telaio di montaggio	13
2.2 Montage Wechseldeckel Aufputz	15

Over deze handleiding	5
Leveringsomvang	6
Vorbereiding	6
1 Inbouwmontage	7
1.1 Afstelling van het montageframe	7
1.2 Afmetingen afdekplaat	8
1.3 Vul de afdekplaat in	9
1.4 Montage inbouw afdekplaat	10
2 Opbouwmontage	13
2.1 Afstelling van het montageframe	13
2.2 Montage opbouw afdekplaat	15

DE

Über diese Anleitung

Herstelleradresse

Gebr. Kemper GmbH + Co. KG
Harkortstraße 5, 57462 Olpe
Tel.: +49 2761 891-0
Web: www.kemper-group.com

Kundendienst

Service-Hotline
Tel.: +49 2761 891 800
Mail: anwendungstechnik@kemper-group.com

Über diese Anleitung

Lesen Sie diese Anleitung vor Montagebeginn oder Gebrauch sorgfältig und folgen Sie den Anweisungen! Bewahren Sie die Anleitung zur späteren Verfürgung auf!

Abbildungen in dieser Anleitung dienen dem grundsätzlichen Verständnis und können von der tatsächlichen Ausführung abweichen.

Haftung

Der Hersteller leistet keine Gewährleistung oder Haftung bei:

- Nichtbeachten dieser Anleitung.
- fehlerhaftem Einbau und/oder Gebrauch.
- eigenständiger Modifikation am Produkt.
- sonstiger, fehlerhafter Bedienung

FR

A propos de cette notice

Adresse du fabricant

Gebr. Kemper GmbH + Co. KG
Harkortstraße 5, 57462 Olpe
Tél.: +49 2761 891-0
Site Internet: www.kemper-group.com

Service après-vente

Ligne d'assistance téléphonique du service après-vente
Tél.: +49 2761 891 800
E-mail: anwendungstechnik@kemper-group.com

A propos de cette notice

Lisez soigneusement la notice avant le montage ou l'utilisation et respectez les instructions!

EN

About this manual

Manufacturer's address

Gebr. Kemper GmbH + Co. KG
Harkortstraße 5, 57462 Olpe
Tel.: +49 2761 891-0
Web: www.kemper-group.com

After-sales service

Service hotline
Tel.: +49 2761 891 800
Email: anwendungstechnik@kemper-group.com

About this manual

Read this manual carefully before starting assembly, use and maintenance and follow the instructions! Retain the manual for later reference!

Illustrations in this manual serve to aid basic understanding and may differ from the actual system configuration.

Liability

The manufacturer assumes no warranty or liability in case of:

- failure to follow these instructions
- incorrect installation and/or use
- unauthorised modification of the product
- other improper methods of operation.

Conservez la notice comme référence à l'avenir!

Les illustrations de cette notice ont pour but de donner au lecteur une compréhension de base et peuvent diverger du modèle existant.

Responsabilité

Le fabricant n'assume aucune responsabilité ni aucune garantie:

- en cas de non-respect de cette notice,
- en cas d'installation et/ou d'utilisation incorrecte(s),
- en cas de modification autonome du produit et
- en cas de toute autre utilisation inappropriée.

IT

Informazioni su queste istruzioni

Indirizzo del produttore

Gebr. Kemper GmbH + Co. KG
Harkortstraße 5, 57462 Olpe
Tel.: +49 2761 891-0
Web: www.kemper-group.com

Servizio clienti

Service-Hotline
Tel.: +49 2761 891 800
E-mail: anwendungstechnik@kemper-group.com

Informazioni su queste istruzioni

Leggere con attenzione le presenti istruzioni prima di procedere al montaggio e all'utilizzo. Attenersi alle indicazioni fornite! Conservare le istruzioni per poterle consultare in seguito! Le immagini riportate in queste istruzioni hanno lo scopo di agevolare la comprensione di base e possono differire dall'effettiva versione dell'impianto.

Responsabilità

Il produttore non fornisce alcuna garanzia né si assume alcuna responsabilità in caso di:

- mancata osservanza delle presenti istruzioni
- installazione e/o utilizzo errato
- modifica arbitraria del prodotto
- altro impiego non conforme.

NL

Over deze handleiding

Adres van de fabrikant

Gebr. Kemper GmbH + Co. KG
Harkortstraße 5, 57462 Olpe
Tel.: +49 2761 891-0
Web: www.kemper-group.com

Technische dienst

Service hotline
Tel.: +49 2761 891 800
Mail: anwendungstechnik@kemper-group.com

Over deze handleiding

Lees deze handleiding zorgvuldig door voordat u begint met de installatie en het gebruik en volg de instructies op! Bewaar deze handleiding goed, zodat u haar later weer kunt raadplegen! Afbeeldingen in deze handleiding dienen voor het begrip van de werking en kunnen afwijken van de daadwerkelijke uitvoering.

Aansprakelijkheid

De fabrikant verleent geen garantie en stelt zich niet aansprakelijk bij:

- het negeren van deze handleiding
- incorrecte inbouw en/of incorrect gebruik
- eigenmachtige wijziging van het product
- andere foutieve bediening.



Lieferumfang · Scope of delivery · Contenu de livraison ·
Fornitura in dotazione · Leveringsomvang

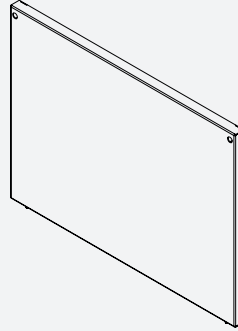

Vorbereitung · Preparation · Préparatifs · Preparazione ·
Voorbereiding

1

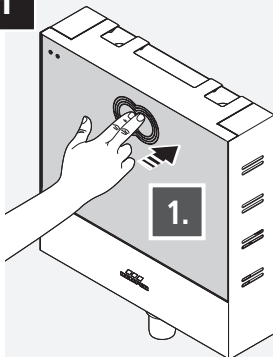

2.

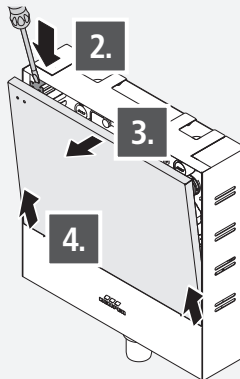

3.

4.



- DE **Info!** Demontage des serienmäßigen Wechseldeckels
- EN **Info!** Disassembly of standard reversible cover
- FR **Info!** Démontage du couvercle interchangeable
- IT **Info!** Smontaggio del coperchio intercambiabile standard
- NL **Info!** Demontage van het standaard wisselplaat

1

Unterputzmontage · Flush-mounted installation · Montage encastré · Montaggio a incasso · Inbouwmontage

1.1

Ausrichtung des Einbaurahmens · Alignment of mounting frame · Alignement du cadre de montage · Allineamento del telaio di montaggio · Afstelling van het montageframe

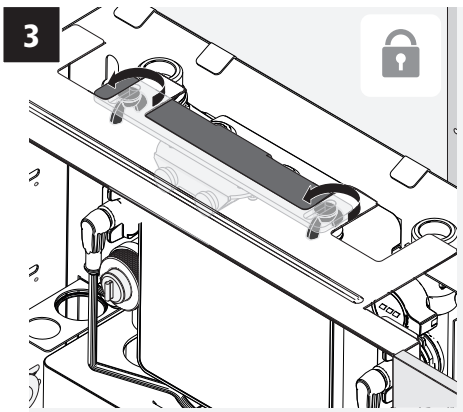
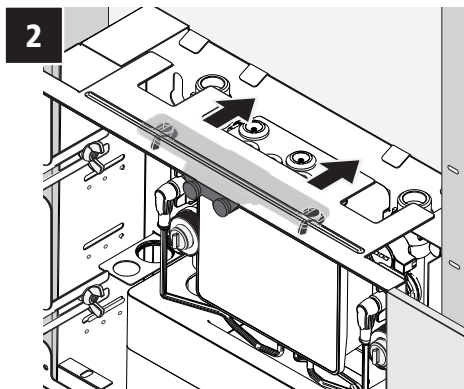
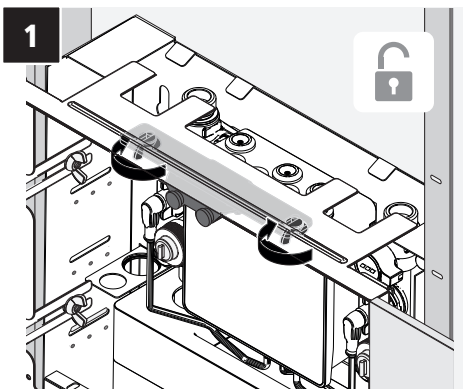

1.2

Abmaße Wechseldeckel · Dimensions reversible cover · Dimensions du couvercle · Dimensioni telaio di coperchio intercambiabile · Afmetingen afdekplaat

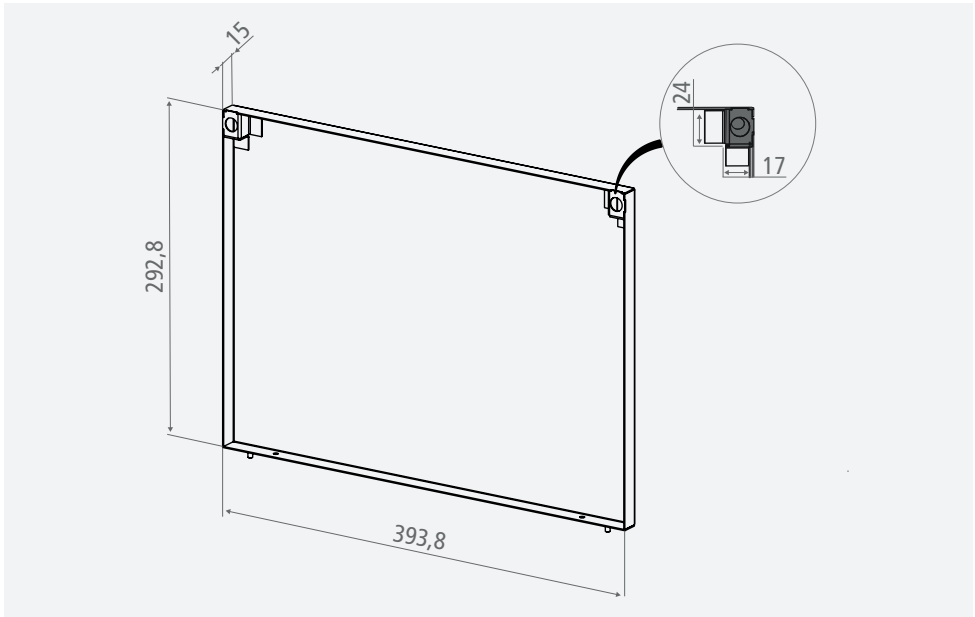

1.3

Wechseldeckel ausfüllen · Fill in reversible cover · Remplir le couvercle interchangeable · Compilare coperchio intercambiabile · Vul de afdekplaat in

1

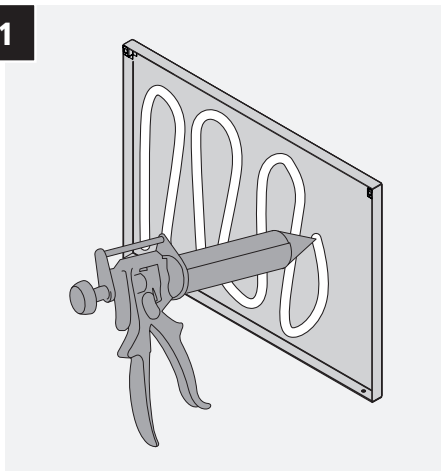

2

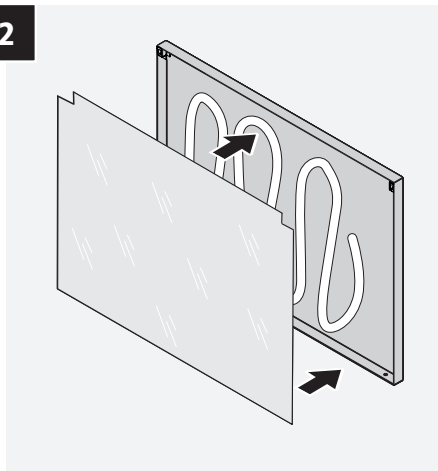

3

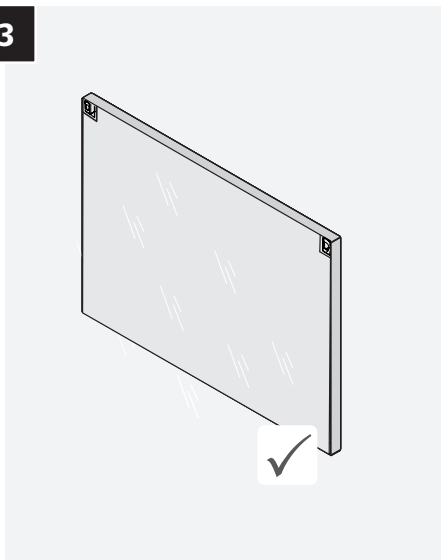

i

2

3

- DE Info!** Die Füllungen des Wechseldeckels sollten tiefenbündig mit den Außenkanten abschließen. Trocknungszeit berücksichtigen.
- EN Info!** The infills on the reversible cover should be flush with the outer edges. Allow for drying time.
- FR Info!** Les remplissages du couvercle interchangeable doivent être, en profondeur, à fleur des bords extérieurs. Respectez le temps de séchage.
- IT Info!** Le parti imbottite del coperchio intercambiabile devono chiudersi a filo con i bordi esterni. Tenere presente il tempo di asciugatura.
- NL Info!** De vullingen van de afdekplaat moeten vlak afsluiten met de buitenranden. Droogtijd in acht nemen.

1.4

Montage Wechseldeckel Unterputz · Installation flush-mounted reversible cover · Montage du couvercle interchangeable incasté · Montaggio di coperchio intercambiabile incasso · Montage inbouw afdekplaat

A

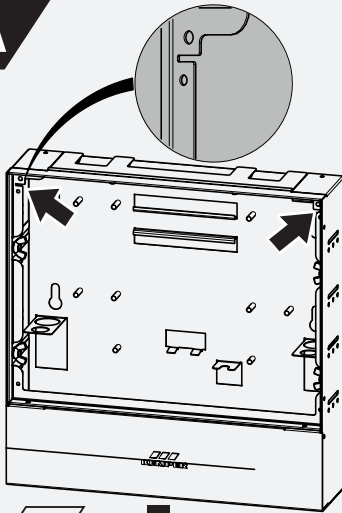

i



DE **Info!** Ab Baureihe 01.01.2024
 EN **Info!** From series 01.01.2024
 FR **Info!** À partir de la série 01.01.2024
 IT **Info!** Dalla serie 01.01.2024
 NL **Info!** Vanaf serie 01.01.2024

B

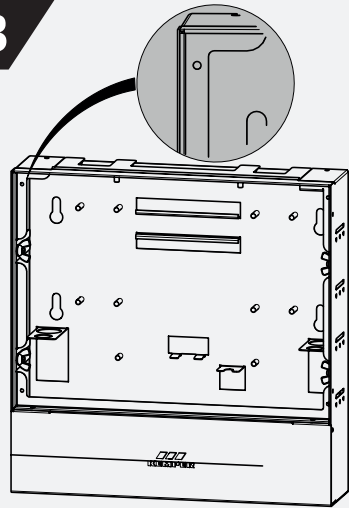

1

A



2.

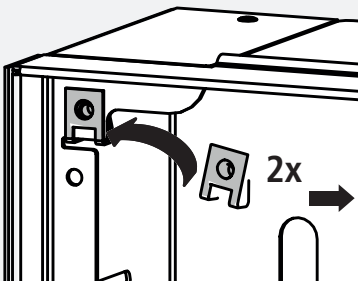

1.4

Montage Wechseldeckel Unterputz · Installation flush-mounted reversible cover · Montage du couvercle interchangeable incasté · Montaggio di coperchio intercambiabile incasso · Montage inbouw afdeklaat

2 A

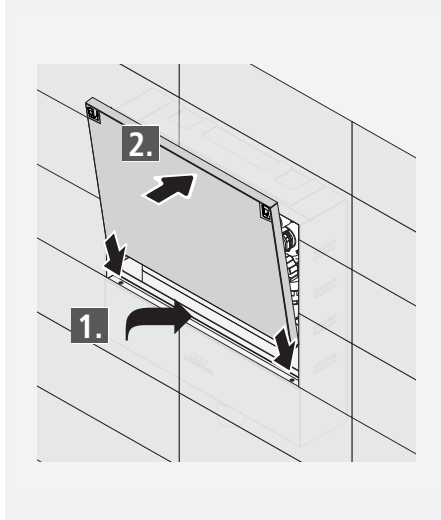

1 B

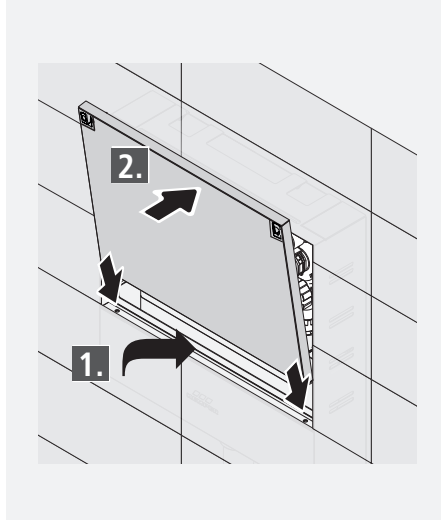

3 A

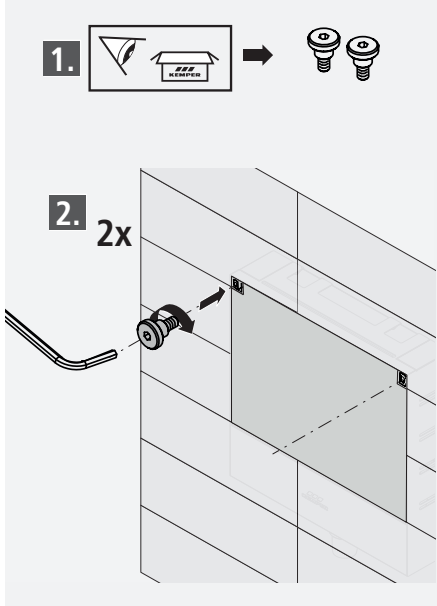

2 B

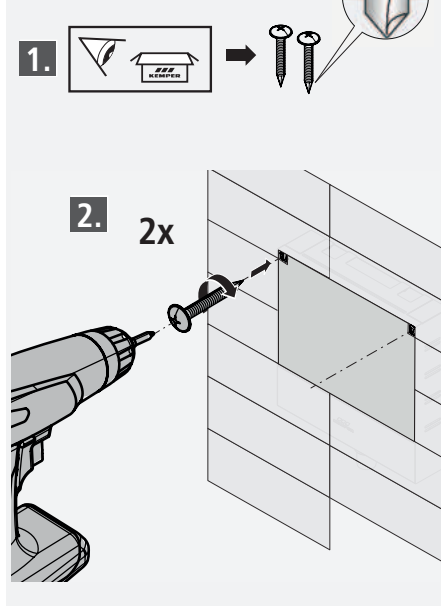

1.4

Montage Wechseldeckel Unterputz · Installation flush-mounted reversible cover · Montage du couvercle interchangeable incasté · Montaggio di coperchio intercambiabile incasso · Montage inbouw afdekplaat

4 A

1.



2. 2x

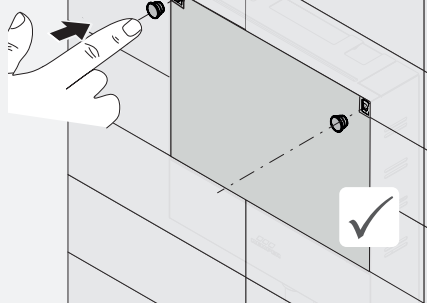

3 B

1.



2. 2x

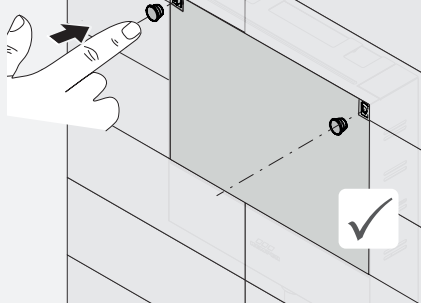

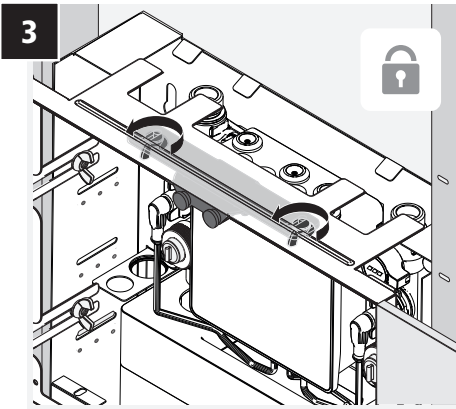
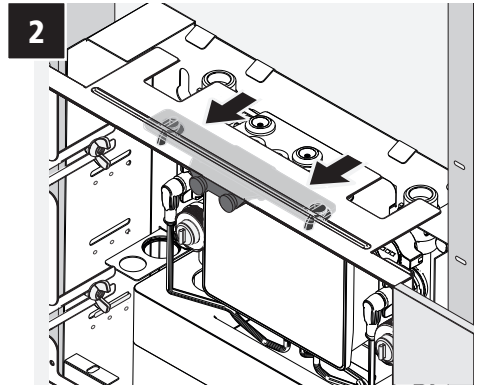
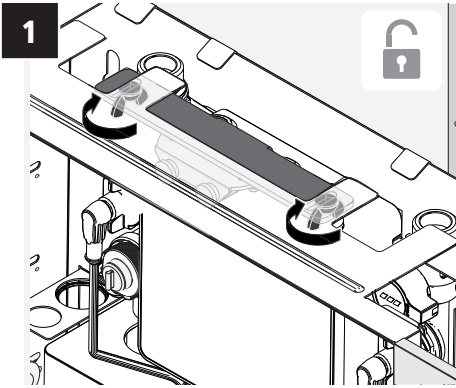
2**Aufputzmontage · Surface-mounted installation · Montage apparent · Montaggio a parete · Opbouwmontage****2.1****Ausrichtung des Einbaurahmens · Alignment of mounting frame · Alignement du cadre de montage · Allineamento del telaio di montaggio · Afstelling van het montageframe**

2.2

Montage Wechseldeckel Aufputz · Installation surface-mounted reversible cover · Montage du couvercle interchangeable apparent · Montaggio di coperchio intercambiabile a parete · Montage opbouw afdekplaat

A

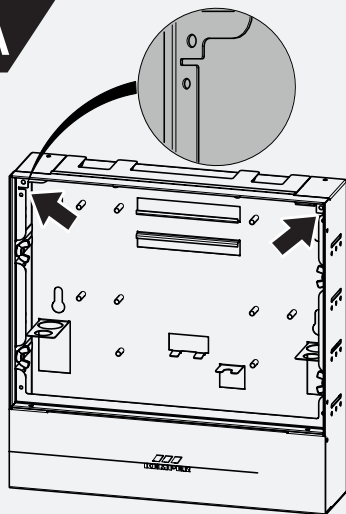

i



DE **Info!** Ab Baureihe 01.01.2024
 EN **Info!** From series 01.01.2024
 FR **Info!** À partir de la série 01.01.2024
 IT **Info!** Dalla serie 01.01.2024
 NL **Info!** Vanaf serie 01.01.2024

B

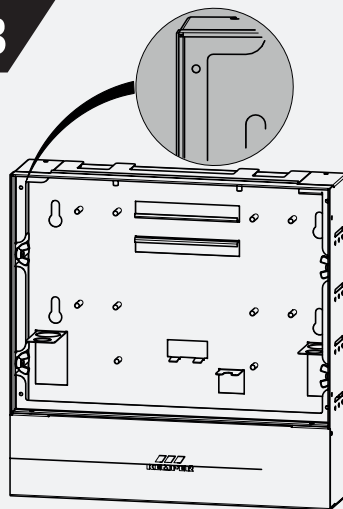

1

A



2.

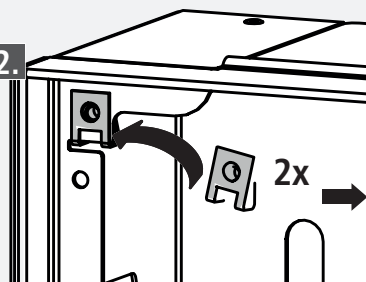

2.2

Montage Wechseldeckel Aufputz · Installation surface-mounted reversible cover · Montage du couvercle interchangeable apparent · Montaggio di coperchio intercambiabile a parete · Montage opbouw afdekplaat

2 A

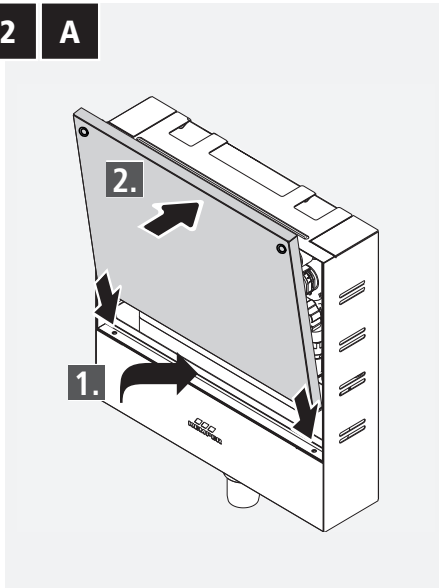

1 B

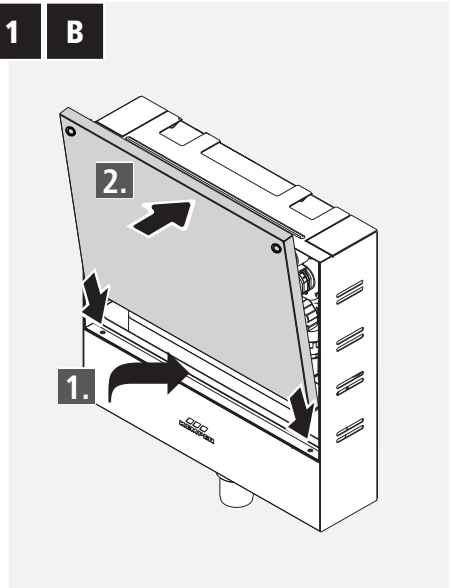

3 A

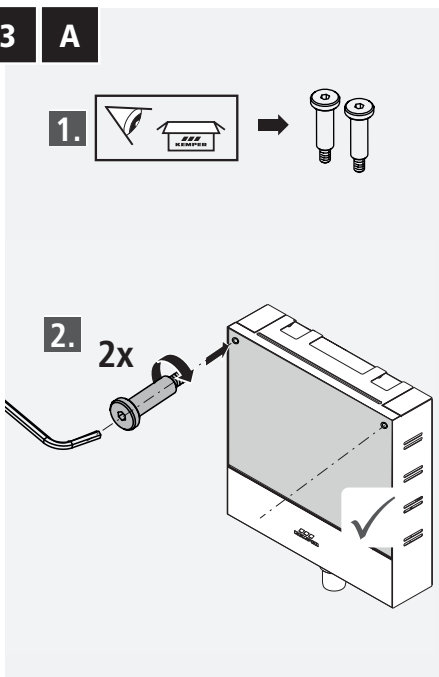

2 B

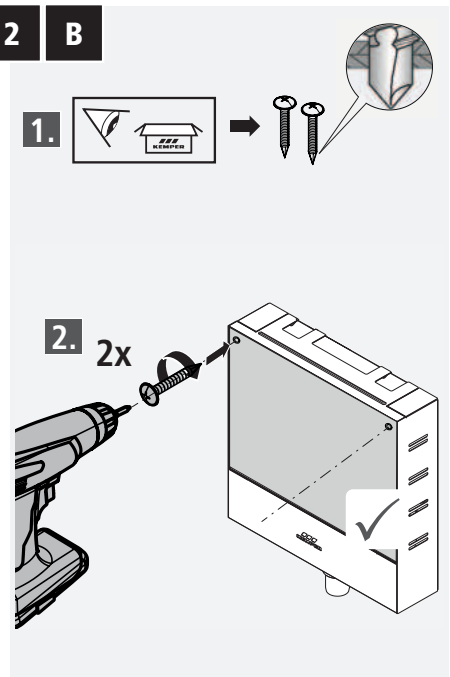

FORTSCHRITT MACHEN

Gebr. Kemper GmbH + Co. KG
Harkortstraße 5
D-57462 Olpe



Service-Hotline +49 2761 891-800
www.kemper-group.com
info@kemper-group.com

K410068903020-00 / 08.2024