

Installation and Operating Instructions

3-directional reversing valve

Figure 916 02 32 | 916 02 40 | 916 02 50 |
916 02 65 | 916 02 80



DN 32 - DN 50



DN 65 - DN 80



Table of Contents

About this manual	2
Safety information	3
Scope of delivery	4
1 Technical Data	4
2 Functional Principle	6
3 Assembly and Installation	8
3.1 Assembly	8
3.2 Direction of Flow and Installation	
Instructions	
Preparing the 3-Way valve	
• DN 32 to DN 50	10
• DN 65 to DN 80	12
4 Mains Connection and Terminal Assignment	16
4.1 Connection to the Mains Grid	16
4.2 Connection Situation	19
5 Commissioning and Functional Check	19
6 Maintenance and Repair	20

Original Operating Instructions

Manufacturer's address

Gebr. Kemper GmbH + Co. KG
Harkortstrasse 5
57462 Olpe, Germany
Tel: +49 2761 891-0
Web: www.kemper-group.com

Customer Services

Service Hotline
Tel: +49 2761 891 800
Email: anwendungstechnik@kemper-group.com

About this Manual

Read this manual carefully before starting assembly, commissioning, use and maintenance and follow the instructions!

Always pass the instructions on to the current operator and keep in a safe place for later use! Illustrations in this manual serve to aid basic understanding and may differ from the actual system configuration.

About this manual



This manual is protected by copyright. Copyright lies with the manufacturer.

Target group

This manual is intended for plumbing and electrical specialists who carry out the installation and commissioning of the water heater. It is also intended for the user of the controller software and the operator

Personnel qualifications

Assembly and installation of the system may only be carried out by plumbing specialists who have been additionally trained in the field of electrical installation. They must be familiar with drinking water hygiene and be able to carry out standard-compliant maintenance work and lay and connect electrical cables.

We particularly refer to VDE regulation 0100 and the regulations of the relevant local power utility.

Liability

The manufacturer assumes no warranty or liability in case of:

- failure to follow these instructions
- incorrect installation and/or use
- unauthorised modification of the product
- other improper methods of operation.

Assembly

Before commencing assembly, read the instructions carefully and follow all directions. Pass these instructions on to the operator and retain for later reference!



Warning!

Assembly and maintenance is to be carried out only by competent and qualified professionals.



Warning!

Priority must be given to the national standards and provisions on plumbing and electrical installation and accident prevention.



Safety Instructions for Assembly, Commissioning, Function and Maintenance



Note!

The product may be installed only in dry rooms.

Warning Information

Be sure to read and follow the warning information in the instructions. Failure to follow the warning information can result in injury or damage to property.

Labelling for important warning information:



Danger! Electricity!

Indicates hazards that may result in severe or fatal injury.



Warning!

Indicates hazards that may result in injury, material damage or contamination of drinking water.



Note!

Indicates hazards that may result in system damage or malfunctions.



Info

Indicates additional information and tips.

Important advice for the operator

Intended use

The 3-way valve is intended solely for use in combination with KEMPER KTS water heater. In combination with one or more KEMPER KTS Water Heater(s), the job of the 3-way valve is to redirect the return water coming from the water heater to the lower or middle connection of the ThermoTank, depending on the pre-set temperature. For that purpose, the 3-way valve is linked with the KTS controller unit.

Flawless operation can only be guaranteed when the information in this manual are taken into account. Use the water heater only in enclosed spaces in buildings with ambient air and without aggressive gases and liquids. The 3-way valve must only be used for heating water.

Use the system:

- in perfect condition
- as intended.



Danger! Electricity!

Danger of fatal electric shock!
Work on live components entails an immediate risk of a fatal electric shock.



Disposal

Local regulations on waste recycling and disposal must be followed. The product must not be disposed of with household waste but must be disposed of properly.

Flawless operation can only be guaranteed when the steps and information in this manual are complied with.

Standards and directives

The thermostat controller meets the stipulations of the EU directives on electromagnetic compatibility, 2004/108/EC, and the EEC Directive on electrical devices for use within certain voltage limits (Low voltage directive) 2006/95/ EEC.

The device complies with the following standards or normative documents:

DIN EN 60730-1 DIN EN 60730-2-9
DIN EN 60730-2-14 DIN EN 55014-2
DIN EN 61000-6-1 DIN EN 61000-6-2
DIN EN 61000-6-3

To create and operate the plant, comply with the generally accepted codes of practice and the building inspection and legal stipulations.



DN 32 - DN 50

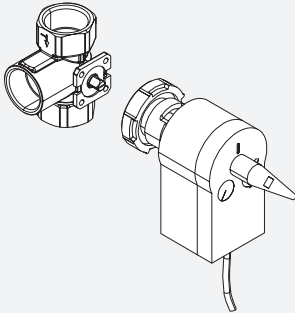

DN 65 - DN 80

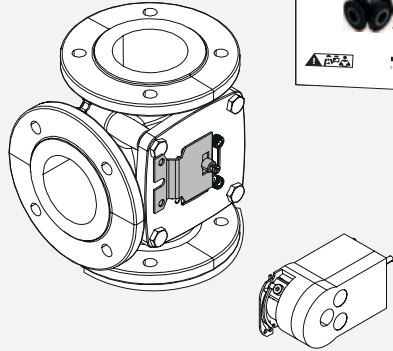

1

Technical data

DN 32 - DN 50

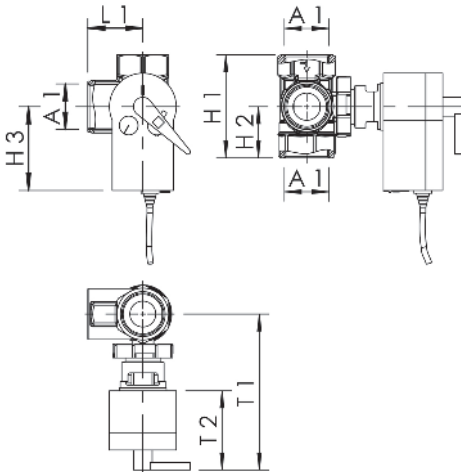

DN 65 - DN 80

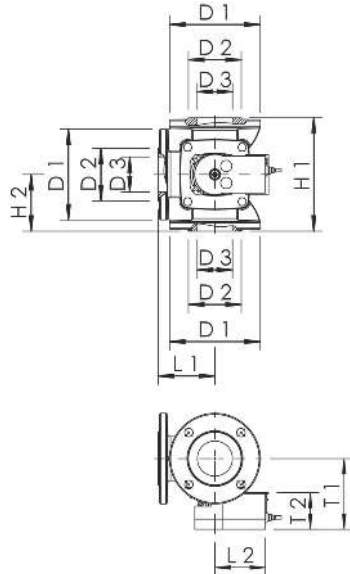

DN 32 Part no. 9160203200	
A1	Rp 1 ¼
H1 (mm)	99
H2 (mm)	49,5
H3 (mm)	89
L1 (mm)	53
L2 (mm)	67
T1 (mm)	160,5
T2 (mm)	84
Flow coefficient value	16
kg	1,03

DN 40 Part no. 9160204000	
A1	Rp 1 ½
H1 (mm)	110
H2 (mm)	55
H3 (mm)	89
L1 (mm)	58
L2 (mm)	67
T1 (mm)	166,5
T2 (mm)	84
Flow coefficient value	25
kg	1,44

DN 50 Part no. 9160205000	
A1	Rp 2
H1 (mm)	132
H2 (mm)	66
H3 (mm)	89
L1 (mm)	68
L2 (mm)	67
T1 (mm)	179,5
T2 (mm)	84
Flow coefficient value	40
kg	2,37

DN 65 Part no. 9160206500	
Number of boreholes	4
D1 (mm)	160
D2 (mm)	93
D3 (mm)	61
H1 (mm)	200
H2 (mm)	100
H3 (mm)	110
L1 (mm)	100
L2 (mm)	89
T1 (mm)	125
T2 (mm)	63
Flow coefficient value	100
kg	9,7

DN 80 Part no. 9160206500	
Number of boreholes	8
D1 (mm)	190
D2 (mm)	118
D3 (mm)	80
H1 (mm)	240
H2 (mm)	120
H3 (mm)	110
L1 (mm)	160
L2 (mm)	89
T1 (mm)	140,5
T2 (mm)	63
Flow coefficient value	150
kg	15,96

Operating principle

The temperature controlled KTS 3-way valve is used in combination with the KEMPER Water Heater and the KTS ThermoTank.

The job of the 3-way valve is to redirect the return water coming from the water heater to the lower or middle connection of the ThermoTank, depending on the pre-set temperature on the controller.

The purpose is to promote the formation of low-temperature layers in the bottom section of the ThermoTank.

If the return temperatures are higher, e.g., in circulation mode, the return water is redirected to one of the middle connections.

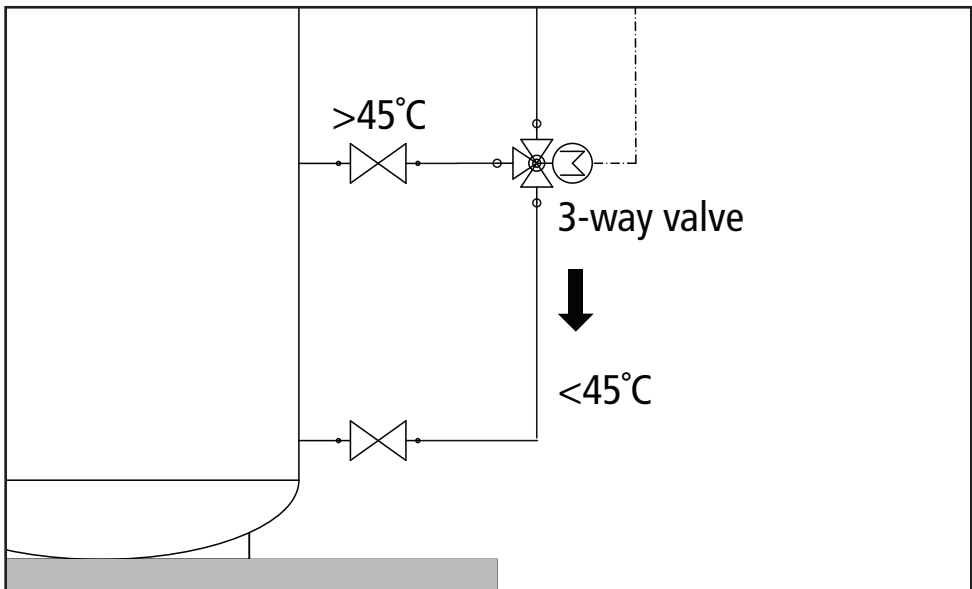

Figure 1 - Schematic diagram of the 3-way valve.

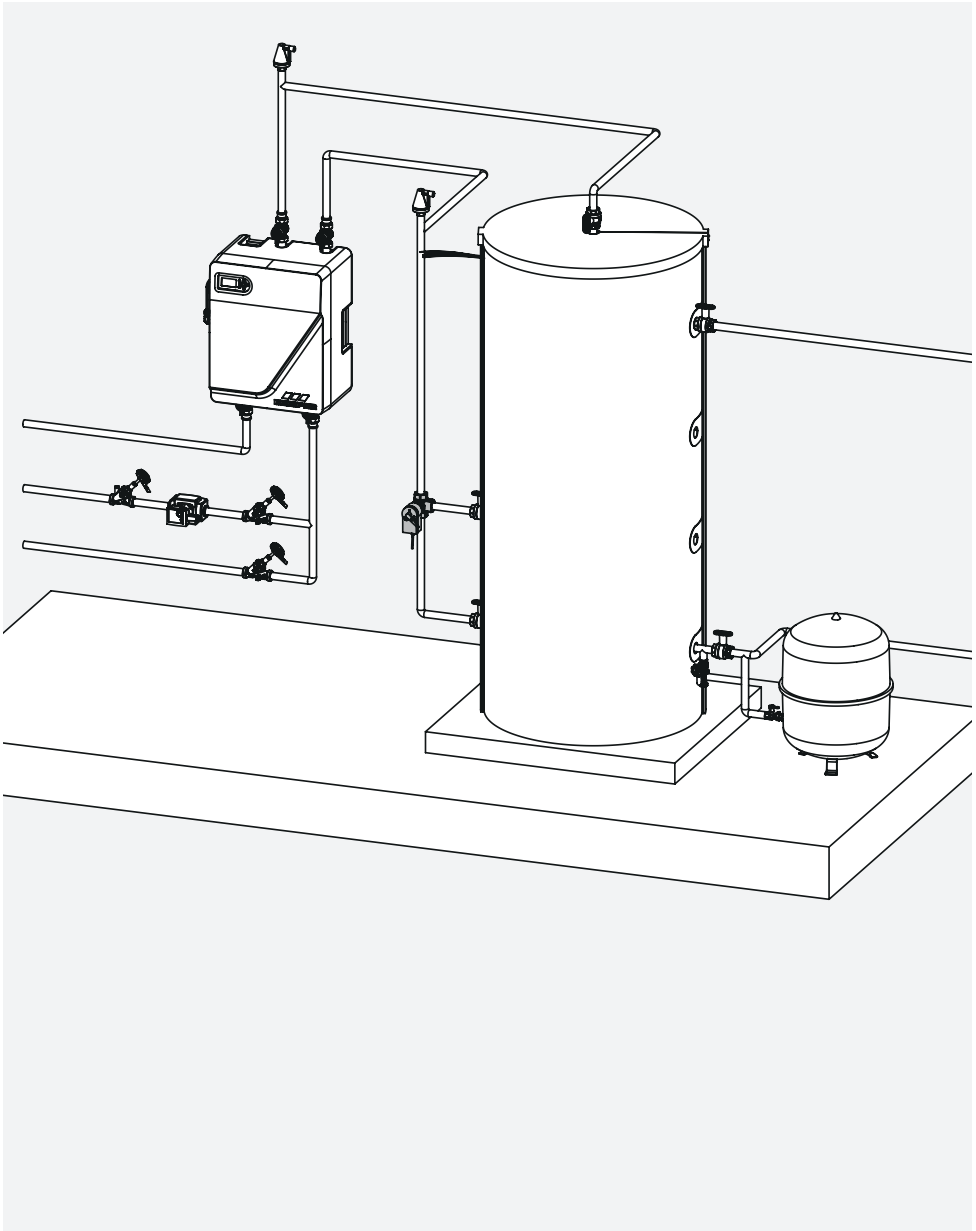

Figure 2 - Schematic diagram.

3

Assembly and installation

General Information

For maintenance purposes, during installation place the heating pipes in the primary ventilation/air extraction equipment at the highest point (see Figures 3 and 4) and drainage facilities at the lowest point.



Note!

For maintenance and repair purposes, provide maintenance valves equipment at the respective heating supply and return connection of the KTS Water Heaters and at the ThermoTank.



Note!

In order to save energy, the valve must be insulated in accordance with the requirements in the German Buildings Energy Act (GEG).

3.1

Assembly

Place KTS the 3-way valve in the shared heating-side return pipe in the direction of flow after the KTS Water Heaters towards the KTS ThermoTank (see Figure 3).



Note!

The DENDRIT hydraulics diagram of the KTS drinking water heating plant shows the point at which the middle connections of the buffer tank are connected.

Installation Instruction

- 1** Close the supply of the KTS 3-way valve (see direction of flow) on the shared return-flow.
- 2** Connect one outlet of the valve to one of the middle connections of the Thermo Tank.
- 3** Connect the valve's through-outlet to the bottom connection of the ThermoTank.

3.1

Assembly

Hydraulic linking of the 3-way valve in association with a KTS ThermoTank.

1 3-way valve with actuator



Note!
Comply with the direction of flow of the valve when mounting/installing!

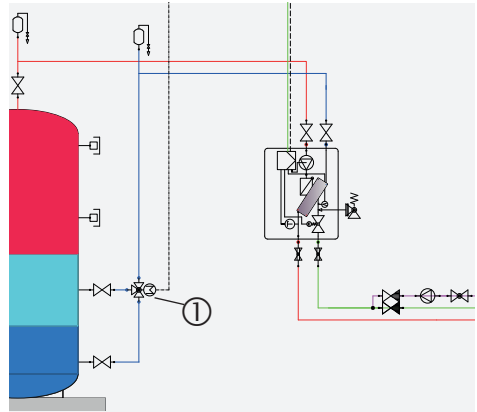

Figure 3

Hydraulic linking of the KTS 3-way valve with several KTS ThermoTanks:

1 3-way valve with actuator



Note!
When installing the 3-way valve in combination with multiple Thermo Tanks, it is mandatory that the hydraulic equalization is performed by installing in accordance with the Tichelmann principle. That applies to both the primary circuit and to the secondary circuit.

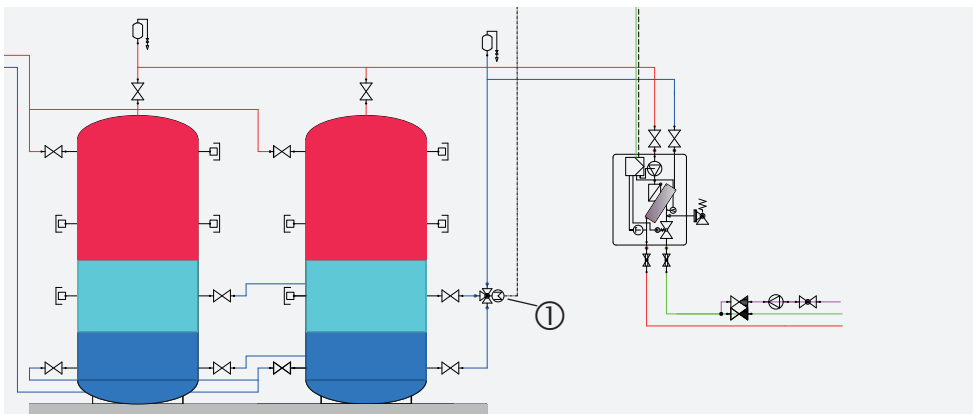

Figure 4

3.2

Direction of Flow and Installation Layout

Preparing the 3-way valve DN 32 to DN 50



Normative information!

- Software Class A
- Pollution degree II
- Type 1AB
- Peak voltage strength 4,000V

DIN EN 60730

Installation situation with outlet left

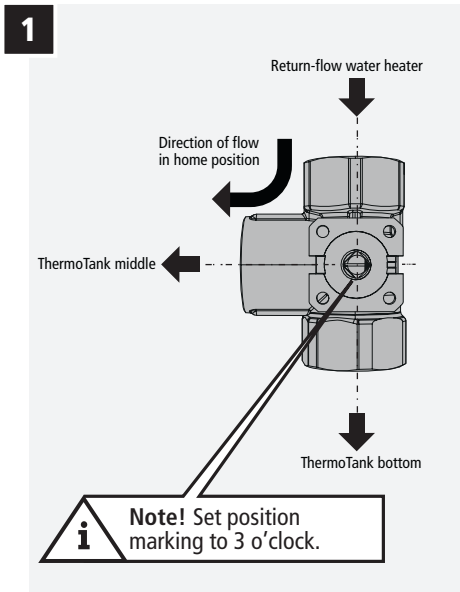

Figure 5 - Position marking.

Installation situation with outlet right

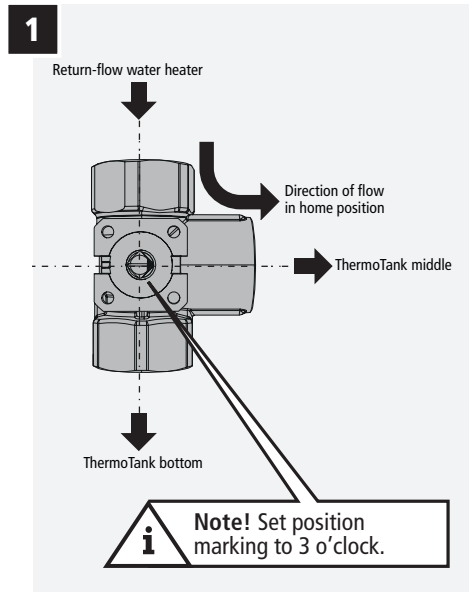

Figure 6 - Position marking.

Installation situation with outlet left

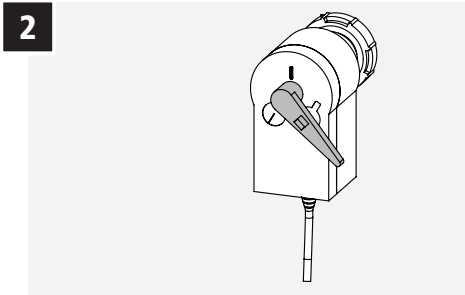

Figure 7 - Set the stop of the actuator to the right (100%).

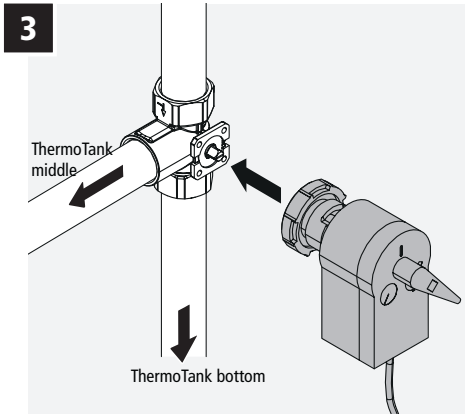
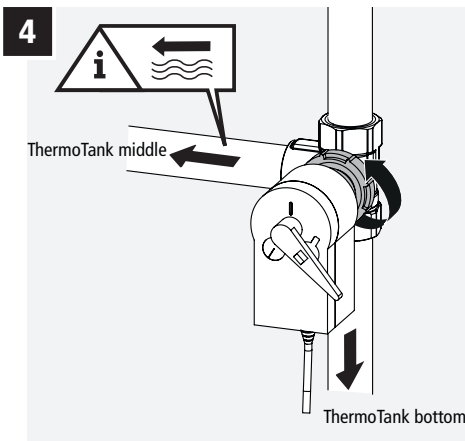

Figure 9 - Plug the actuator on the valve



Installation situation with outlet right

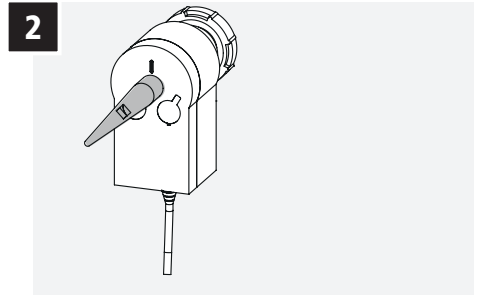

Figure 8 - Set the stop of the actuator to the left (0%).

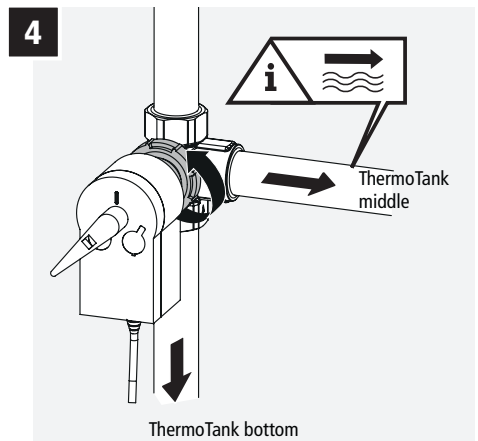
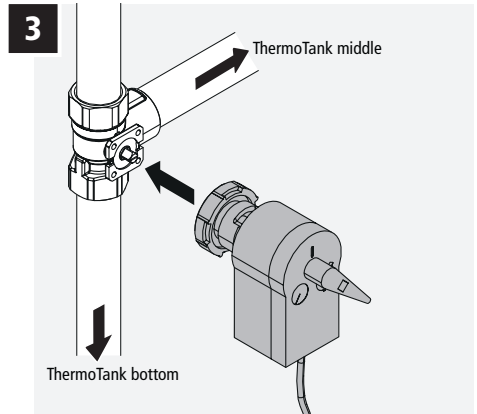

Figure 10 - Turn the lock by um 45° to fix the actuator on the valve.

3.3

Direction of Flow and Installation Layout

Preparing the 3-way valve DN 65 to DN 80



Normative information!

- Software Class A
- Pollution degree II
- Ball pressure text 129 °C
- Type 1AB
- Peak voltage strength 4,000V

DIN EN 60730

Einbausituation mit Abgang links

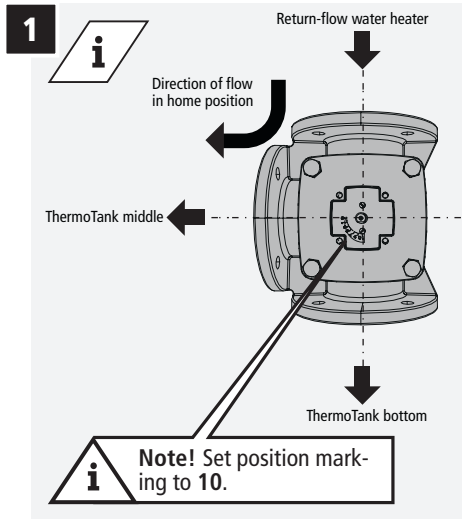

Figure 11

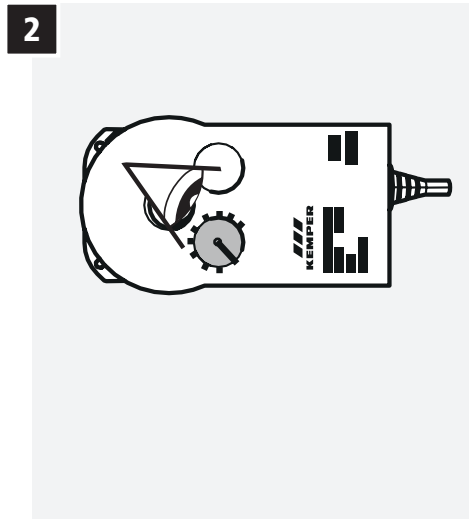

Figure 12 - Set the stop of the actuator to the left (100%).

3.3

Direction of Flow and Installation Layout

Installation situation with outlet left

3

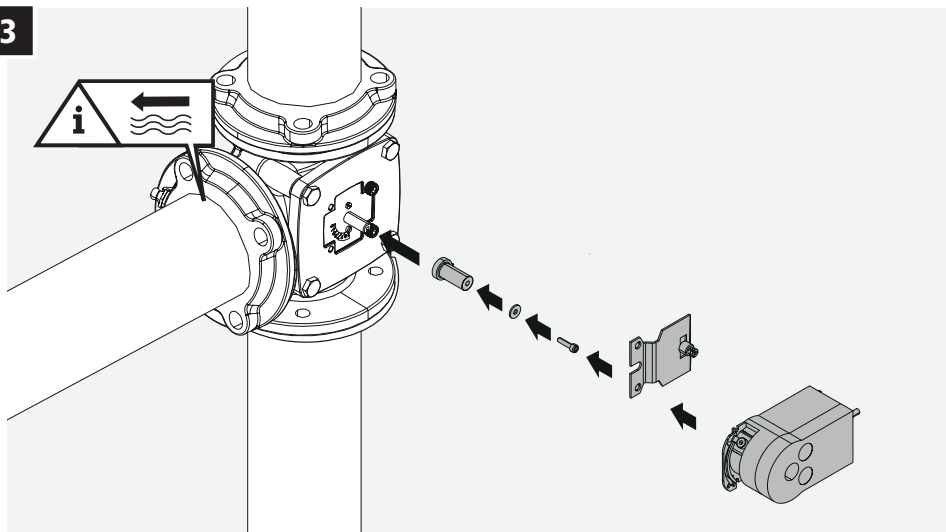

Figure 13 - Plug the actuator on the valve

4

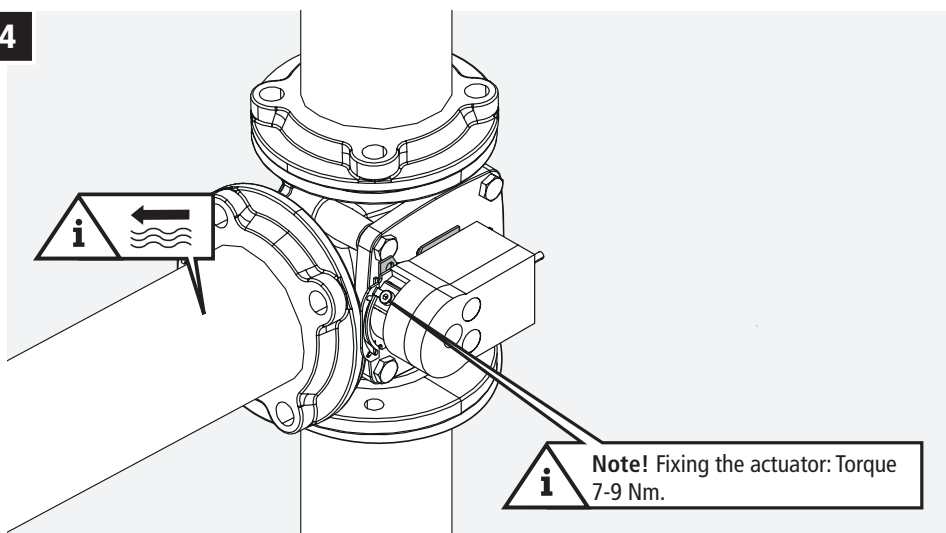

Figure 14 - Fixing the actuator: Torque 7-9 Nm.

3.3

Direction of Flow and Installation Layout

Installation situation with outlet right

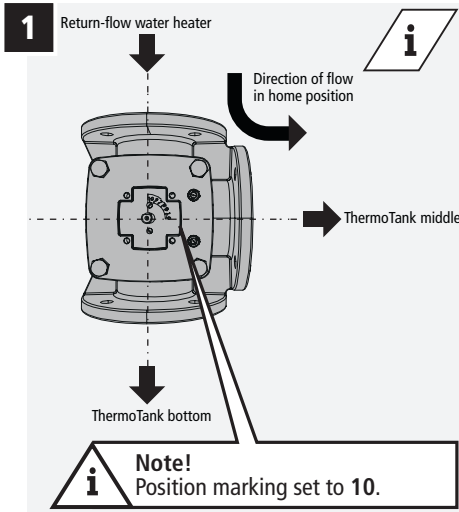

Figure 15 - Position marking.

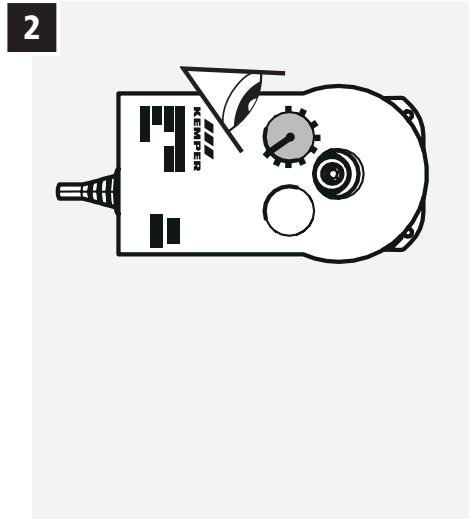

Figure 16 - Set the stop of the actuator to the right (0%).

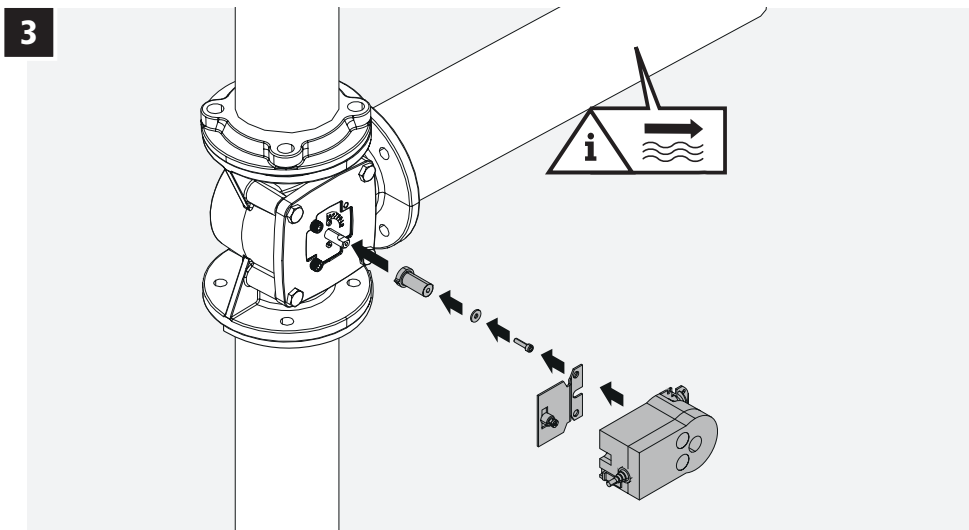

Figure 17 - Plug the actuator on the valve.

3.3

Direction of Flow and Installation Layout

Installation situation with outlet right

3

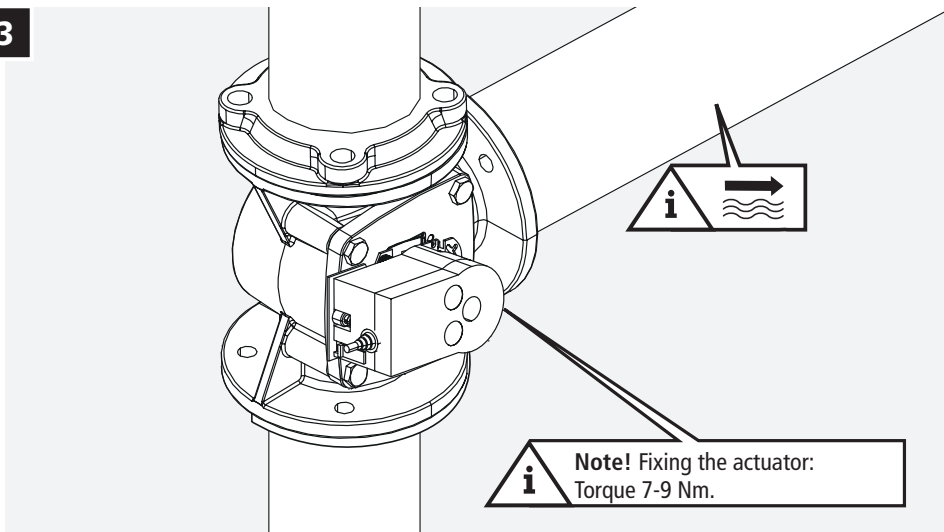

Figure 18 - Fixing the actuator: Torque 7-9 Nm.

4

Mains Connection and Terminal Assignment

4.1

Connection to the Mains Grid

Have a skilled tradesmen make the electrical connection to the mains grid (~230 V / 50 Hz) in accordance with the relevant local power utility and VDE directives. It must be possible to cut-off

the 230 V mains feed pipe with a switch. The use of a junction box is recommended. The wiring is visualised below:

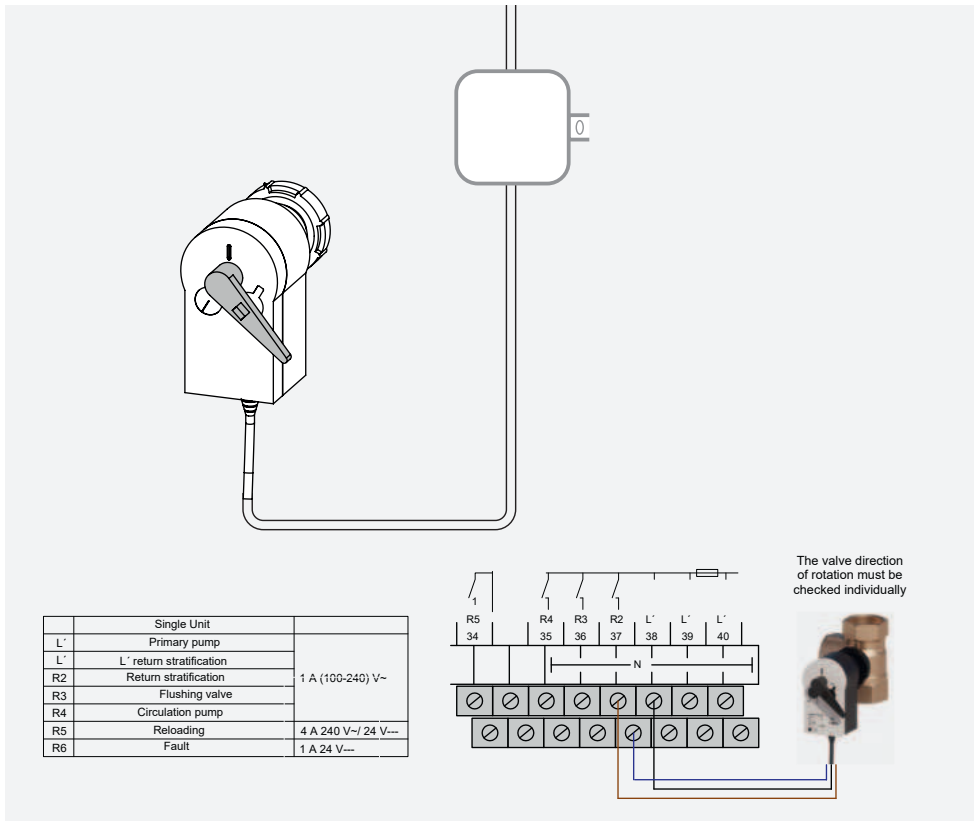

Figure 19 - The switched phase of the 3-way valve is connected to R2 of Cascade Station 1 or single unit. The constant current of the valve is applied to terminal 38.

4.2

Connection Situation

Outlet left and right (DN 32 to DN 80)

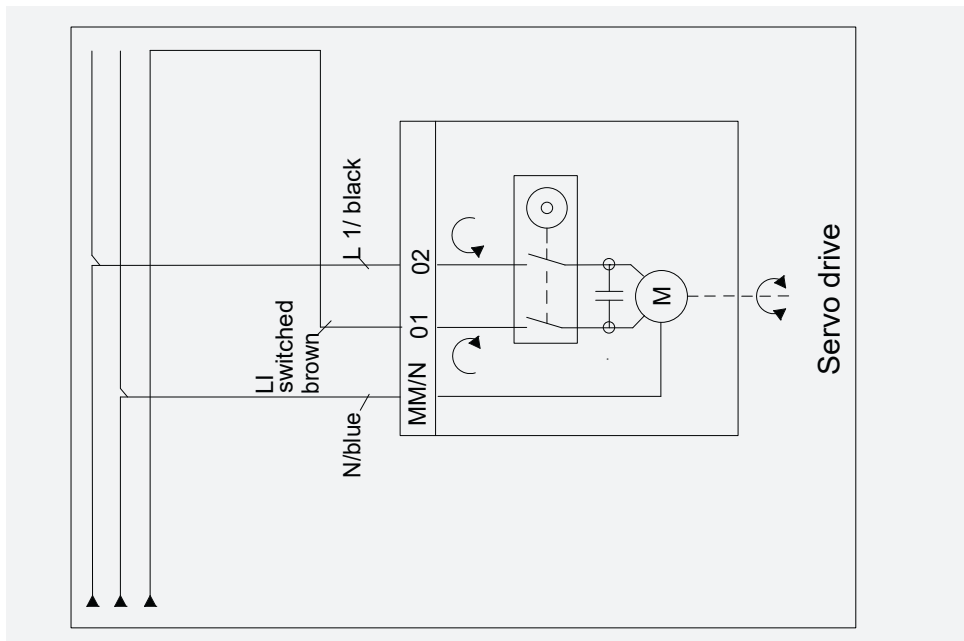

Figure 20

5

Commissioning and Functional Test

1. Fill the ThermoTank and primary circuit with water until operating pressure has been reached.
2. Check the installation for leaks.
3. The temperature can be set via the controller (45°C is preset).
4. Carry out the functional test of the 3-way valve (PWH draw-off).



Warning! Incomplete venting of the system leads to malfunctions and will damage the plant components.



Note! If the installation direction is incorrect or if the valve cone in the 3-way valve is set incorrectly, the PWH temperature will not be reached! The necessary primary flow rate will not be achieved.

According to DIN EN 806-5, the drinking water heating system must be maintained annually.

Kemper recommends performing the following measures on the 3-way valve during maintenance.

Temperature-controlled 3-directional reversing valve	Implementation	Defect/Complaint	Date
Check the actuator for its functioning, installation position rights	Set the temperature in the controller to max. temp. -> Actuator moves to 100% -> Set the temperature in the controller to min. temp. -> Actuator moves to 0% -> Set 45°C		
Check the actuator for its functioning, installation position left	Set the temperature in the controller to max. temp. -> Actuator moves to 0% -> Set the temperature in the controller to min. temp. -> Actuator moves to 100% -> Set 45°C		
Check the controller for its functioning.	See previous step		
Check the valve for leaks	Visual check		
Check the valve function	When carrying out the functional test of the actuator, check the temperature in the outlet after the valve.		



KEMPER
DRIVING PROGRESS

Gebr. Kemper GmbH + Co. KG
Harkortstraße 5
D-57462 Olpe



Service-Hotline +49 2761 891-800
www.kemper-group.com
info@kemper-group.com

K41 0091600012-ON / 09.2024